

The 13th Japanese TRIZ symposium

Re-establishment of awareness of an existing product
by TRIZ application

MIZUSHIMA PRESS KOGYO Co., Ltd.
Engineering Department development group
Takanori Suzuki



Contents

- Company overview
- Background and purpose of TRIZ introduction
- Activity
- Result
- View in the future



Company



Name of the company Ltd. of Press Kogyo Mizushima

Establishment March, 1953

Employee 286 people

Activities Equipment manufacturing for transportation
(Steering wheel shaft, Door hinge Another)

Headquarters Okayama Prefecture Kurashiki City

Production foothold Kurashiki factory, Mitsu factory, and Tokushima factory

Foreign countries Joint venture company MMWI (Indonesia), SCMP (China)



Steering wheel column Assembly



Passenger car



Track



Construction machinery



Machine for agriculture

Steering wheel shaft



Passenger car



Track

Various door hinges for car



Passenger car Door hinge

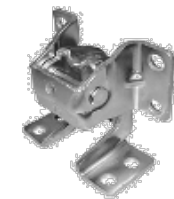

Track Door hinge



Company

Our plastic forming

It is possible to correspond also to the undercut shape.

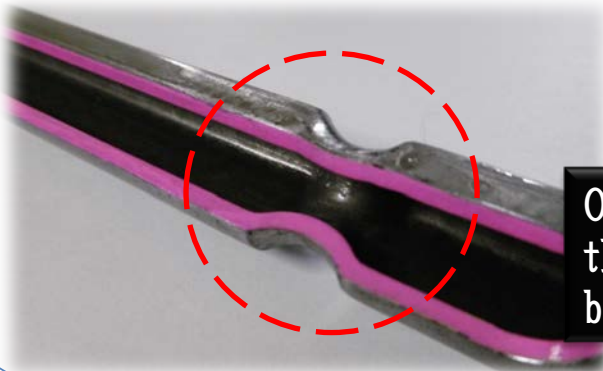

Swayze processing

Our company squeezes to molding of the steering wheel shaft, and Swayze besides the processing is employed.



Various hinges for car

Plastic forming



Steering wheel shaft

Press working



Sheet metal yoke for universal collaboration

Background and purpose of TRIZ introduction

Car and parts in recent years



Car



- Lightening with low fuel cost target
- Making of power [seito]
- Comfortable operativeness



Auto parts



- Lightening each parts
- Shaking decrease between parts

Better each parts quality is requested.



Background and purpose of TRIZ introduction

Past approach

The cost doesn't fall

It manages to make it by a past way of making.

ery. manage

Vicious circle



Recognition to the product doesn't change.

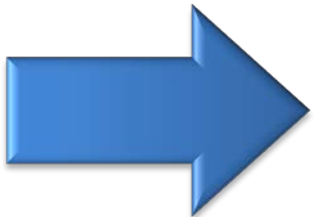

The new paradigm doesn't arise in the one-making.



Background and purpose of TRIZ introduction

It why is this making, and a structure now are not understood.

The technology is not handed down.

It is taught that this is such a thing.

Strong preconception (psychological inertia)

The way is not understood though the cause is understood.

The foundation of the product (problem) is not understood.

Obstruction of idea creation



Background and purpose of TRIZ introduction

It is feeling in a past way as for the limit.
I want to take the conception that not is so far.

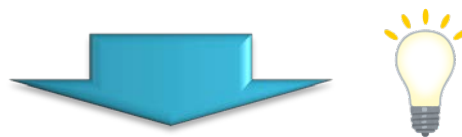

Proposal of "Systematic development technique with
a core of TRIZ" from the idea company Ltd..

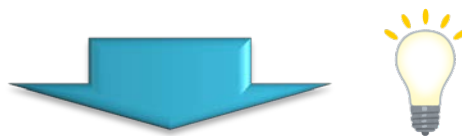

The conception that not is so far is taken and it enters.
Recognition to an existing product is restructured.



Activity

Theme of activity

Universal collaboration
(Cardin collaboration)

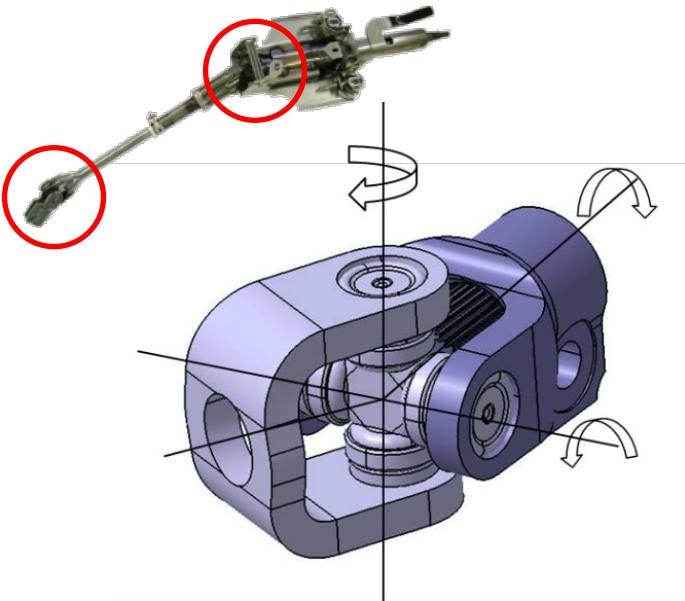

Parts that transmit gyration
input from steering wheel from
various angles

Problem

	パラメータ	影響
回転ガタ		<p>Steering wheel control performance Cause of generation of sound</p> <p>↓</p> <p>The smaller, the better.</p>
折り曲げトルク		<p>Steering wheel control performance</p> <p>↓</p> <p>The more lightly, the better.</p>

究極はどちらも0・・・



Activity

Theme of activity

Development target

Recognition of present goods

If the difference of the rotation is reduced, the bend torque becomes heavy.

- The contradiction characteristic is caused.
- Adjustment by trade-off

I do not want to change present goods and the component formation. . . .

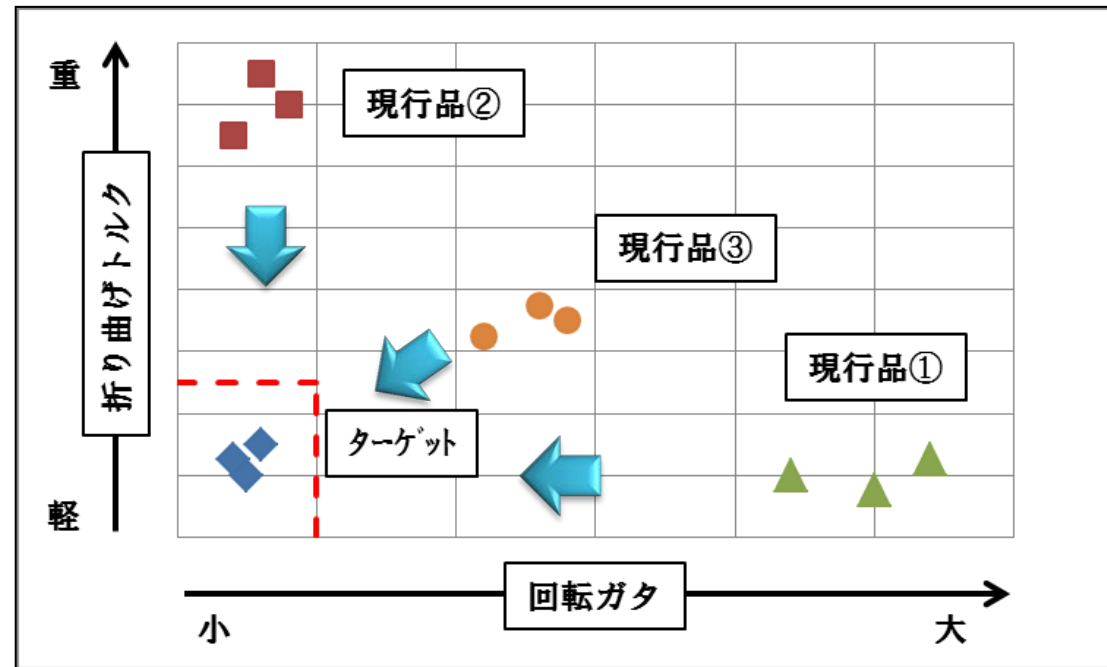

However, . . .

It examines it around the industrial method.



Activity

Process of problem solving

Making of problem essence

Device analysis
(function-attribute analysis)



Foundation cause analysis
(cause-consequence analysis)



Contradiction definition of root problem
(formulation of contradiction)



Idea putting out by TRIZ

Idea putting out
(Invention principle of 40 · Another)



Making of idea effective
(evaluation and combination of idea)



The final concept decision

- Even if the product is different, the same process is traced.
- Mechanism that effective idea is conceived easily



Activity

Making of problem essence

The system of universal collaboration is analyzed.

Device analysis

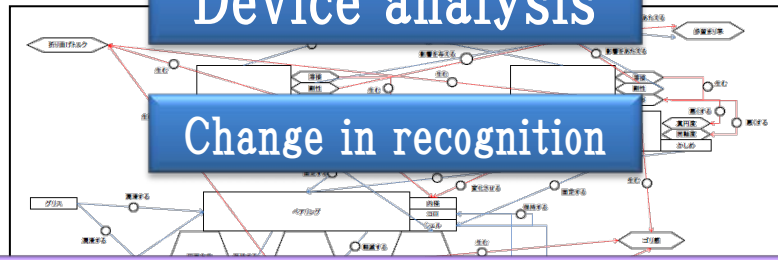

Purpose (output)

Complete parts

The one of essence

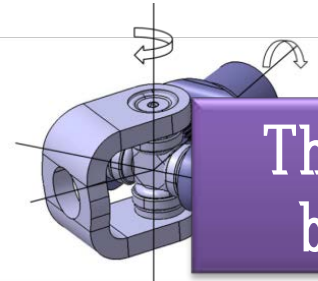

The rotation difference of universal collaboration becomes small by making the bend torque heavy.

is analyzed.

An essential problem of

— does **, the rotation difference of universal collaboration changes, and ** does ×× and the bend torque changes.

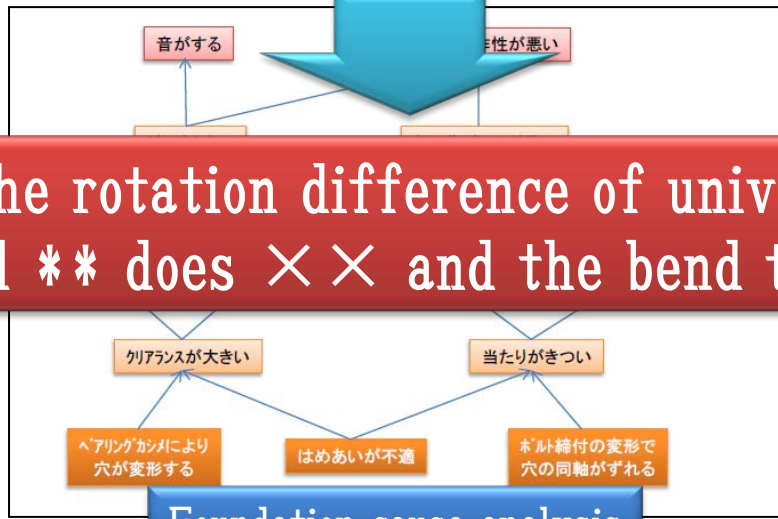
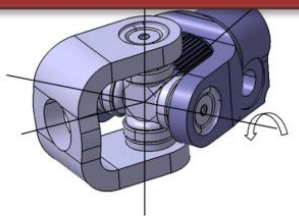

Foundation cause analysis

The problem that should be really planned is pursued.



Activity

Making of problem essence \Rightarrow Idea putting out

Formulation of contradiction

No	例①	
中核問題	鏡が冷たいから	
	TC-1:	暖かい電熱線 \rightarrow 除去する \rightarrow 水滴(曇り) \leftarrow 消費する \leftarrow 電力
	水滴(曇り)を除去するために暖かい電熱線を使うと電力を消費するという問題がある	
	TC-2:	冷たい電熱線 \rightarrow 除去する \rightarrow 水滴(曇り) \leftarrow 消費する \leftarrow 電力
電力を消費するを無くすために冷たい電熱線を使うと水滴(曇り)を除去するが不足するという問題が発生する		
物理的矛盾(記述)		
鏡を暖める為に電熱線は暖かくなければならないが、電力を消費しないためには冷たくなければならない。		
発明原理	強化する特性一 電力を消費する エネルギー損失	
	改善する特性a 1	温度 21.17 35 38
	暖かい電熱線を使う	
	改善する特性b 1	水滴(曇り)を除去する
システム進化パターン	有害作用	
	不足作用	
科学効果/知識検索		
物体を除去する方法は? エネルギーを強化する方法は?		

Contradiction solution matrix

矛盾(発明)の種類	TRIZの40個の発明原理																																	
	1	2	3	4	5	6	7	8	9	10	11	12	13	14	15	16	17	18	19	20	21	22	23	24	25	26	27	28	29	30	31	32	33	34
物理的矛盾	1	2	3	4	5	6	7	8	9	10	11	12	13	14	15	16	17	18	19	20	21	22	23	24	25	26	27	28	29	30	31	32	33	34
技術的矛盾	1	2	3	4	5	6	7	8	9	10	11	12	13	14	15	16	17	18	19	20	21	22	23	24	25	26	27	28	29	30	31	32	33	34

The policy of the idea putting out is decided.

物理的矛盾	1	2	3	4	5	6	7	8	9	10	11	12	13	14	15	16	17	18	19	20	21	22	23	24	25	26	27	28	29	30	31	32	33	34
技術的矛盾	1	2	3	4	5	6	7	8	9	10	11	12	13	14	15	16	17	18	19	20	21	22	23	24	25	26	27	28	29	30	31	32	33	34
物理的矛盾	1	2	3	4	5	6	7	8	9	10	11	12	13	14	15	16	17	18	19	20	21	22	23	24	25	26	27	28	29	30	31	32	33	34
技術的矛盾	1	2	3	4	5	6	7	8	9	10	11	12	13	14	15	16	17	18	19	20	21	22	23	24	25	26	27	28	29	30	31	32	33	34
物理的矛盾	1	2	3	4	5	6	7	8	9	10	11	12	13	14	15	16	17	18	19	20	21	22	23	24	25	26	27	28	29	30	31	32	33	34
技術的矛盾	1	2	3	4	5	6	7	8	9	10	11	12	13	14	15	16	17	18	19	20	21	22	23	24	25	26	27	28	29	30	31	32	33	34
物理的矛盾	1	2	3	4	5	6	7	8	9	10	11	12	13	14	15	16	17	18	19	20	21	22	23	24	25	26	27	28	29	30	31	32	33	34
技術的矛盾	1	2	3	4	5	6	7	8	9	10	11	12	13	14	15	16	17	18	19	20	21	22	23	24	25	26	27	28	29	30	31	32	33	34

Length of rotation difference = body at rest

Bend torque = Power



10: Advance action

28: Mechanical system substitution

Activity

Idea putting out

Rule of idea putting out

Brainstorm method

Negative prohibition and taking
advantage welcome

Facilitator

Promotion of idea creation



The created idea is described
in Post-it.

Invention principle of 40

10: Advance action

解決策: 先取り作用原理



・物体に対して必要な変更の一部またはすべてを事前に行う。
・最も便利な場所から動作の準備を、動作の進行に合わせるようにする。

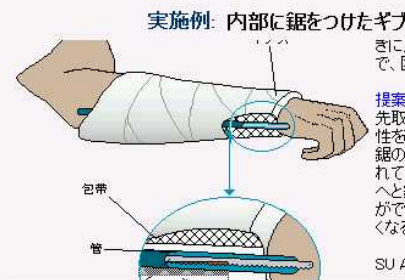

InventionMachine
Goldfire

28: Mechanical system
substitution

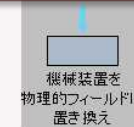

手動に置き換える。
・電界、磁界、電磁界を利用して物体と相互作用させる。
・固定フィールドから可動フィールドに、構造化されていないフィールドから構造化されたフィールドに変更する。

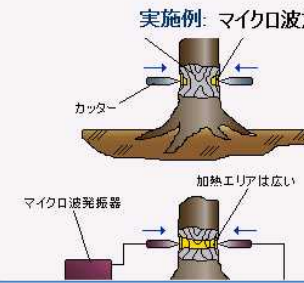

、木材の解凍速度によって切断速度が制限される。

提案
この作業を改善するため、機械的システム代替原理を利用する。マイクロ波を利用し、切断領域を加熱する。木材が解凍され、切断領域が狭くなるため、通常の方法で速く木材を切断できる。

SU A.c. N 741 826

It begins to squeeze the idea by using various
methods including the invention principle of 40.



Activity

Idea putting out

Appearance of idea putting out

Participant

About 250 ideas are created by various methods.

Development section : Three people
 Production technology section : Three people
 Production department : One person
 Fabrication sector : Two people

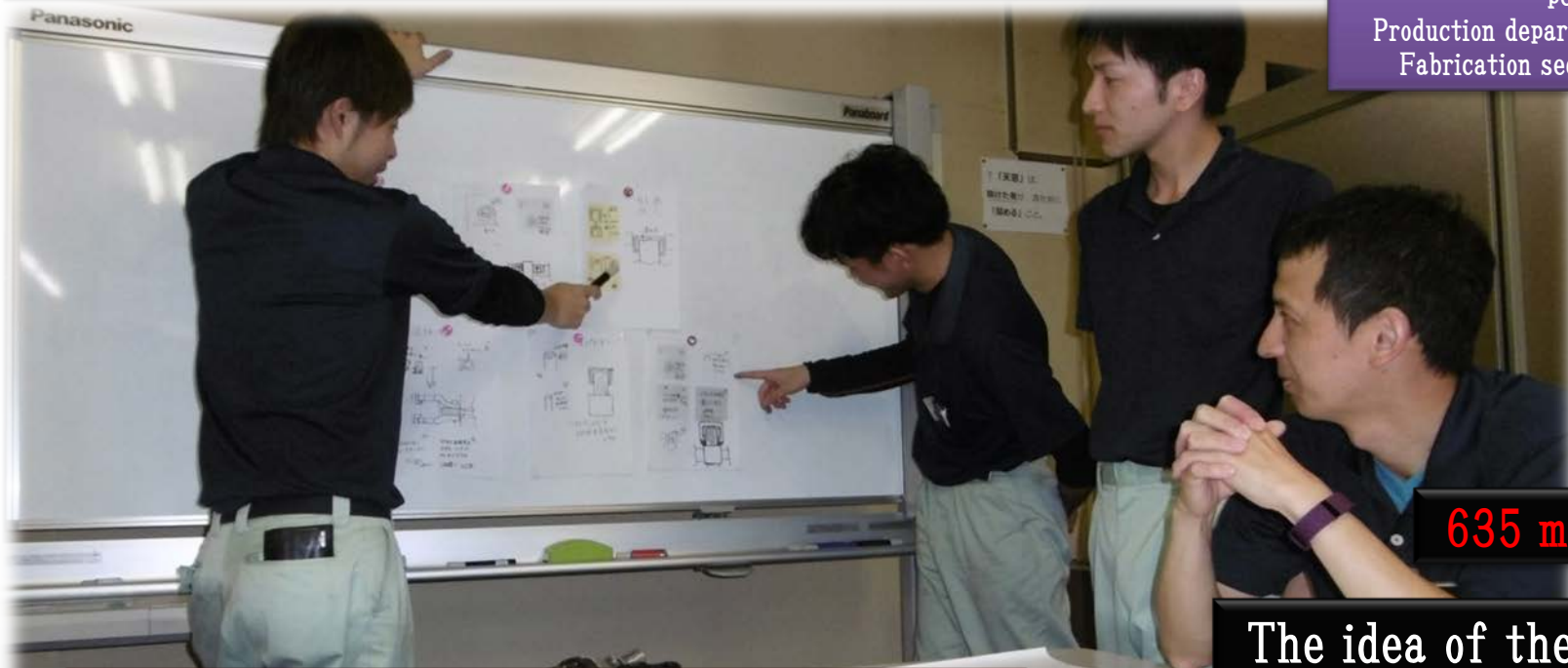

The width of the idea creation extends by participation from various sections.

635 methods

The idea of the time limit of three every five minutes is created.
 It repeats six times.



Activity

Making of idea effective

Uniting of ideas

Created idea of each pivotal question



It classifies it by the subsystem.



Ideas are united and the subconcept is made.



Subconcepts are united and the main concept is decided.

Flow until concept making

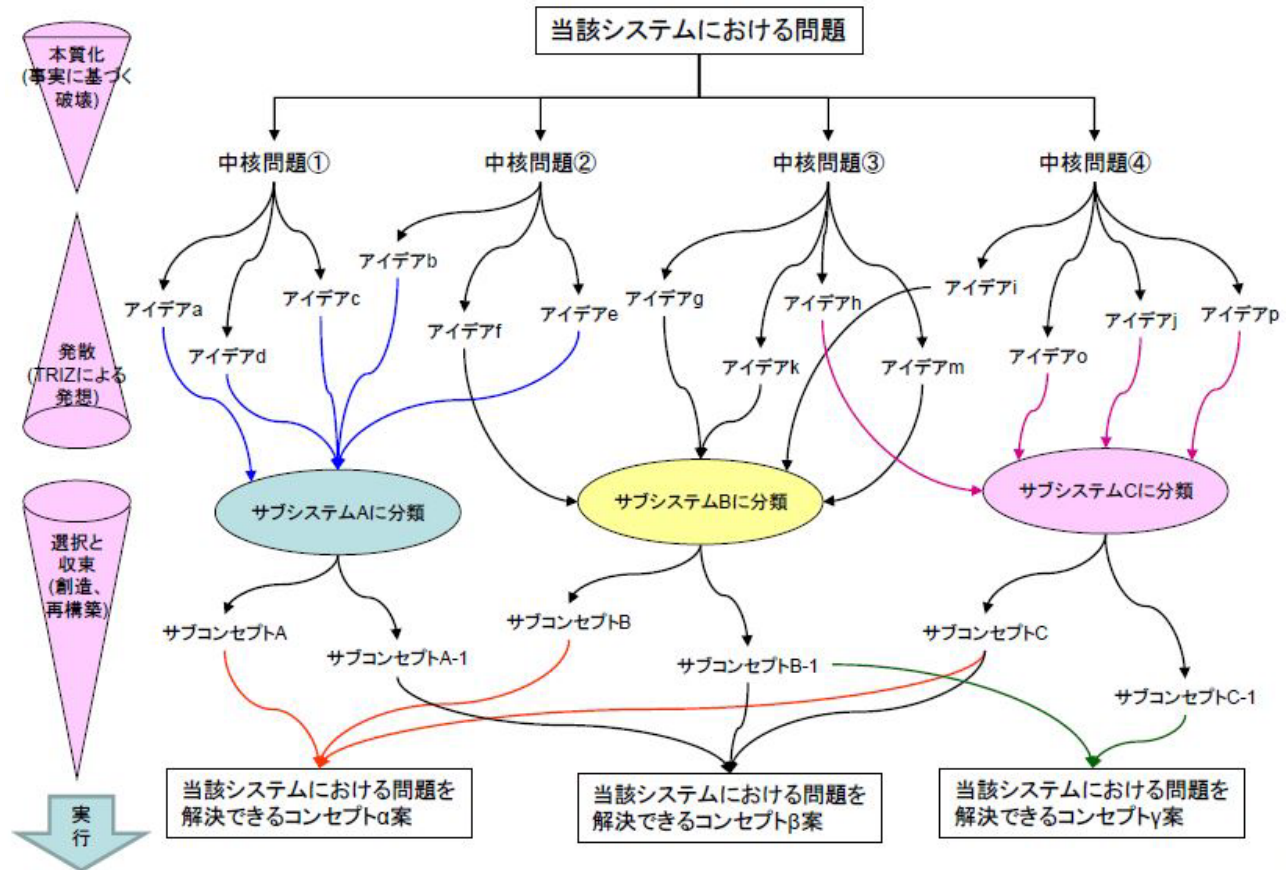

More the number is because the idea is combined and used, the better.



Activity

Making of idea effective

Evaluation of idea

It classifies it by the subsystem.

The comparative assessment against QCD.

サブシステム	Q1	Q2	Q3	C	D
基準					
	S	S	S	S	S
	S	-	S	S	S
	+	-	S	-	-
	-	S	S	S	+
	S	+	-	S	S

Ideas classified by the subsystem are united.



The subconcept is made.

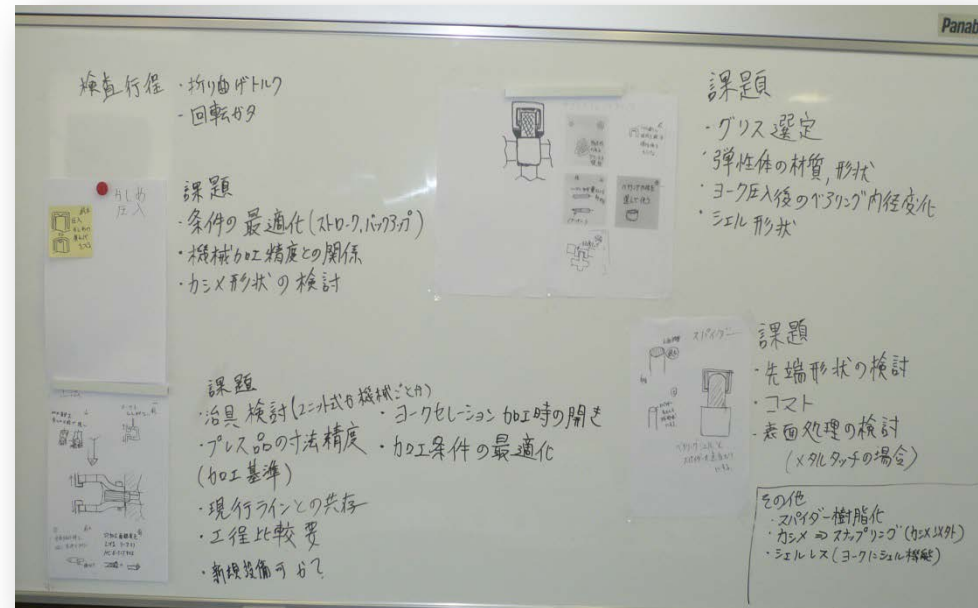

It materializes by combining ideas.



Activity

Making of idea effective

In addition, subconcepts are united.

The main concept making

The treatment device including the strategy of the center problem solving is produced.



Result

Rotation difference

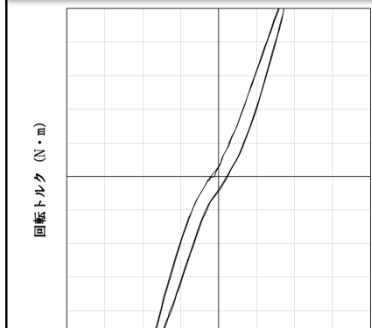

Present goods

Bend torque

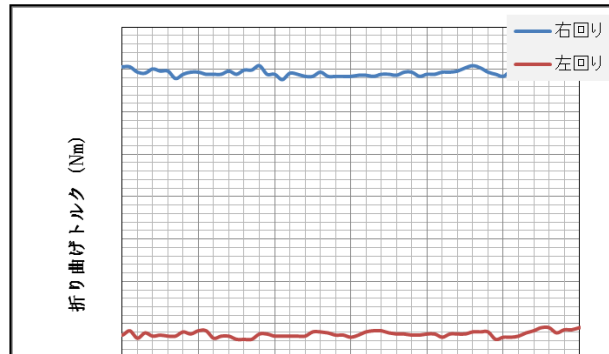

Evaluation

The bend torque is heavy though the rotation difference is small.

Technical contradiction is solved.

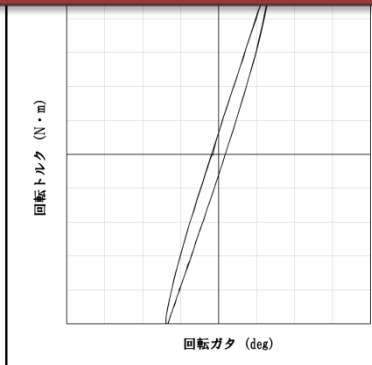

Development goods

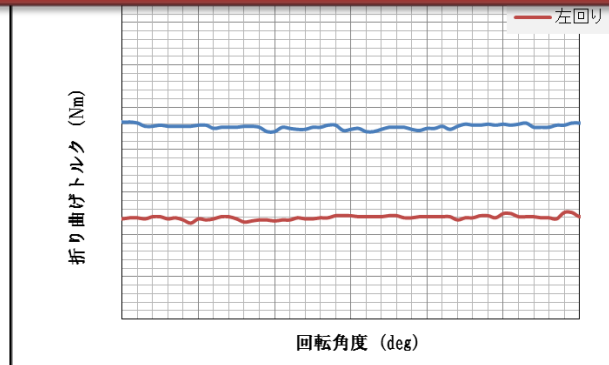

There is no rotation difference, and the bend torque is light.

There is no change it changes and the single goods accuracy of the component formation.



Result

Opinion of activity (personal opinion)



It is standardized as a problem solving method.

Even if the problem (product) is different, it is the same process.



Value having [ri] that does even only foundation cause analysis and device analysis

It is necessary to prepare showing a good idea.



The idea that has come out is not unexpectedly defeated.

It became sensitive for the idea.



The idea achieves a high effect by combining.

To combine and to use it, it puts it out in detail.



TRIZ is wonderful communications tool.

The vector of recognition to the product unites it.



View in the future

Recognition of an existing product is reviewed by using the development technique with a core of TRIZ.

Result

The improvement and the recognition of the performance were able to be renewed.

The young man is mainly developed as a process of the problem solving.

Other products and problems are developed.

Development

Recognition and the approach on the development technique including TRIZ in in-house are strengthened, and other development techniques are introduced.



Address

It proposed the systematic development technique with a core of TRIZ that became a big chance to do this activity.

Idea Ltd. President Zenko

It guided it from the consulting of this activity to the support of this announcement kindly and politely.

Idea Ltd. Mr. Katagiri

Thank you for listening.

